

AMC CD8b

COMPACT DISC PLAYER

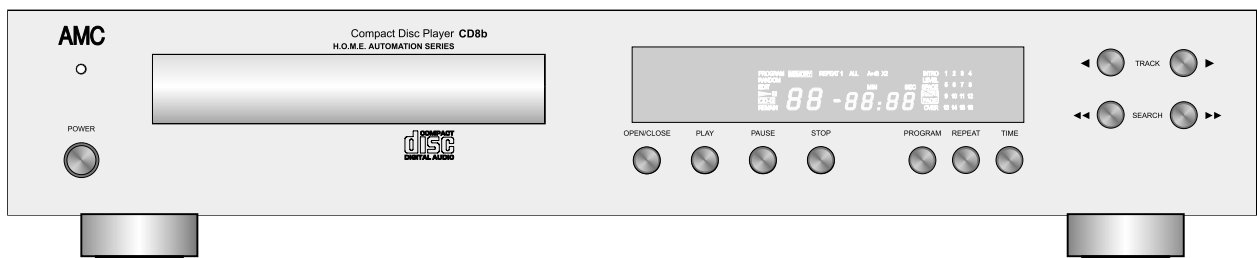

INSTRUCTIONS FOR INSTALLATION AND OPERATION



CAUTION: TO REDUCE THE RISK OF ELECTRIC SHOCK, DO NOT REMOVE COVER (OR BACK). NO USER-SERVICEABLE PARTS INSIDE. REFER SERVICING TO QUALIFIED SERVICE PERSONNEL



AFIN DEVI TER UN CHOC ELECTRIQUE ET LES CONSEQUENCES GRAVES QUI POURRAIENT EN RESULTER, TENTEZ PAS D'OUVRIR L'APPAREIL ET DE TOUCHER AUX COMPOSANTS INTERNES SANS LA PRESENCE D'UNE PERSONNE QUALIFIEE.



PARA REDUCIR EL RIESGO DE SACUDIDAS ELECTRICAS, NO DEBERA QUITARSE LA TAPA (NI PARTE POSTERIOR). CONSULTESE AL PERSONAL CAPACITADO PARA LAS REPARACIONES INTERNAS.

WARNING: TO PREVENT FIRE OR ELECTRIC SHOCK, DO NOT EXPOSE THIS APPLIANCE TO RAIN OR MOISTURE.

ADVERTENCIA: PARA EVITAR EL RIESGO DE INCENDIO O SACUDIDA ELECTRICA, NO DEBERA EXPONERSE ESTE APARATO A LA LLUVIA O HUMEDAD.

CAUTION: TO PREVENT ELECTRIC SHOCK DO NOT USE THIS (POLARISED) PLUG WITH AN EXTENSION CORD, RECEPTACLE OR OTHER OUTLET UNLESS THE BLADES CAN BE FULLY INSERTED TO PREVENT BLADE EXPOSURE..

ATTENTION: POUR PREVENIR LES CHOCS ELECTRIQUES NE PAS UTILISER CETTE FICHE POLARISEE AVEC UN PROLONGATEUR. UNE PRISE DE COURANT OU UNE AUTRE SORTIE DE COURANT, SAUF SILES LAMES PEUVENT ETRE INSEREES A FOND SANS EN LAISSER AUCUNE PARTIE FOND SANS EN LAISSER AUCUNE PARTIE A DECOUVERT.

PRECAUCION: PARA EVITAR SACUDIDAS ELECTRICAS, NO DEBERA UTILIZARSE ESTA CLAVIJA POLARIZADA CON UN CORDON DE PROLONGACION, RECEPTACULO U OTRO TIPO DE SALIDA A MENOS QUE SE HAYAN INSERTASO COMPLETAMENTE LAS LENGÜETAS PARA EVITAR SU EXPOSICION.

NOTE: Some AMC products are equipped with dual or multi-voltage transformers (which is indicated on the back panel). If you wish to change the voltage, please bring your unit to an authorised AMC service technician for internal conversion.

ATTENTION: Quelques pièces AMC sont munies de transformateurs à double ou à multi-voltage (indiqué au panneau arrière). Si vous voulez changer le voltage, veuillez apporter votre appareil au fournisseur de AMC pour le transformer.

ZUR BEACHTUNG: Einige AMC Geräte sind mit Umschaltern für unterschiedliche Netzspannungen ausgerüstet (Ein Vermerk auf der Rückseite weist darauf hin).

Die Anpassung, wenn notwendig, muß von einem qualifizieren Techniker in einer AMC Servicestation vorgenommen werden.

NOTA: Ciertos componentes de AMC están dotados de transformadores de doble tensión o de varias tensiones (lo que se indica en el panel posterior). Si se desea cambiar la tensión, sírvanse llevar el aparato a un técnico autorizado por AMC para su conversión interna.

NOTE TO CATV systems installer: This reminder is provided to call the CATV system installer's attention to Article 820-22 of the NEC that provides guidelines for proper grounding and, in particular, specifies that the cable ground shall be connected to the grounding system of the building, as close to the point of cable entry as practical.

NOTA PARA EL INSTALADOR DE ANTENAS DE TELEVISION COLECTIVAS: La presente advertencia se provee para llamar la atención del instalador al Artículo 820-22 de NEC (Código Eléctrico Nacional) donde se facilitan las directrices para la pertinente puesta a tierra y que especifica en particular que el conductor a tierra del cable debe conectarse al sistema de conexión a tierra del edificio, lo más proximo posible al punto de entrada del cable.

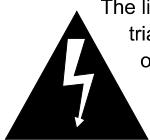

The lightning flash with arrowhead, within an equilateral triangle, is intended to alert the user of the presence of "uninsulated" dangerous voltage" within the product's enclosure; that may be of sufficient magnitude to constitute a risk of electric shock to persons.



The exclamation point within an equilateral triangle is intended to alert the user of the presence of important operating and maintenance (servicing) instructions in the literature accompanying the appliance.

CAUTION

WARNING! INVISIBLE LASER RADIATION WHEN OPEN AND INTERLOCKS DEFEATED. AVOID EXPOSURE TO BEAM.

VORSICHT! UNSICHTBARE LASERSTRAHLEN TRITT AUS, WENN DECKEL GEÖFFNET UND WENN SICHERHEITSVERRIEGELUNG ÜBERBRÜCKT IST. NICHT DEM STRAHL AUSSETZEN.

ADVARSEL- USYNLIG LASERSTRÅLING VED ÅBNING, NÅR SIKKERHEDSAFBRYDERE ER UDE AF FUNKTION. UNDGÅ UDSÆTTELSE FOR STRÅLING.

ADVARSEL- USYNLIG LASERSTRÅLING NÅR DEKSEL ÅPNES OG SIKKERHEDSLÅS BRYTES. UNNGÅ EKSPONERING FOR STRÅLEN.

VARNING- OSYNLIG LASERSTRÅLNING NÅR DENNA DEL ÅR ÖPPNAD OCH SPÄRRAR ÅR URKOPPLADE. STRÅLEN ÅR FARLIG.

VARO!- AVATTAESSA JA SUOJALUKITUS OHITETTAESSA OLET ALLTTIINA NÄKYMÄTÖNNÄ LASERSÄTEILYLLE. ÄLÄ KATSO SÄTEESEEN.

SERVICE SAFETY PRECAUTIONS (UL)

1. Use exact replacement parts for critical locations, marked "△".
2. Return lead dress to original position, and re install protective covers.
3. Before returning to customer, test for shock hazard; use either method A or B:
 - A. Leakage test, "cold":
 1. Unplug AC cord; turn power switch ON.
 2. Connect one lead of High Voltage Insulation Tester to both prongs of AC plug.
 3. Touch other lead to all exposed metal parts.
 4. Impedance measurement must be 0.3-5.0 Megohms.
 - B. Leakage test, "live":
 1. Plug unit directly into AC outlet; do not use isolation transformer.
 2. Connect one lead of Leakage Current Tester to earth ground.
 3. Touch other lead to all exposed metal parts.
 4. Leakage measurement must be less than 0.5 milliamps.

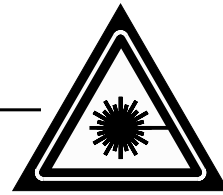
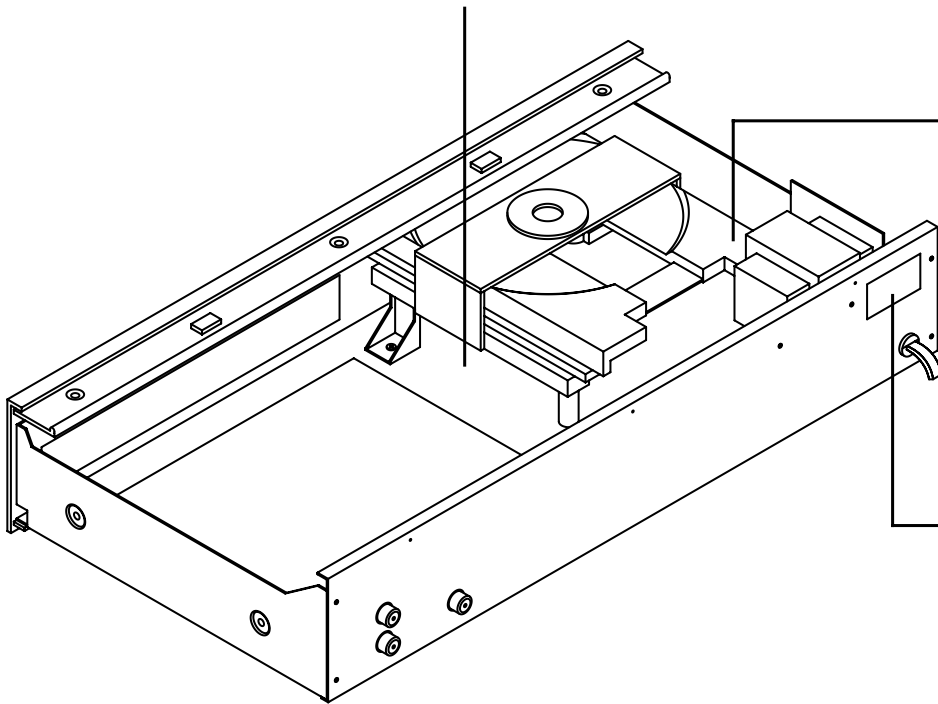

CLASS 1 LASER PRODUCT
LUOKAN 1 LASERPLAITE
KLASS 1 LASERAPPARAT

CAUTION: FOR CONTINUED PROTECTION AGAINST RISK OF FIRE, REPLACE ONLY WITH THE SAME TYPE OF T800mA/250V FUSES.

ATTENTION: POUR MAINTENIR PROTECTION CONTRE RISQUE D'INCENDIE, UTILISER LES FUSIBLES DE RECHANGE DE MEME TYPE DE T800mA/250V.

THIS DIGITAL APPARATUS DOES NOT EXCEED THE CLASS B LIMITS FOR RADIO NOISE EMISSIONS FROM DIGITAL APPARATUS AS SET OUT IN THE RADIO INTERFERENCE REGULATIONS OF THE CANADIAN DEPARTMENT OF COMMUNICATIONS.

LE PRESENT APPAREIL NUMVERIQUE N'EMET PAS DE BRUITS RADIOELECTRIQUES DEPASSANT LES LIMITES APPLICABLES AUX APPAREILS NUMERIQUE DE LA CLASSE B PRESCRITES DANS LE REGLEMENT SUR LE BROUILLAGE RADIO ELECTRIQUE EDICTE PAR LE MINISTERE DES COMMUNICATIONS DU CANADA.

THIS DEVICE COMPLIES WITH PART 15 OF THE FCC RULES. OPERATION IS SUBJECT TO THE FOLLOWING TWO CONDITIONS:

- (1) THIS DEVICE MAY NOT CAUSE HARMFUL INTERFERENCE, AND
- (2) THIS DEVICE MUST ACCEPT ANY INTERFERENCE RECEIVED, INCLUDING INTERFERENCE THAT MAY CAUSE UNDESIRED OPERATION.

APPLICATION AND FEATURE LIST

FEATURES OF THE AMC™ MODEL CD8b

- * The AMC model CD8b was designed to meet professional quality performance standards and to provide superior value.
- * Select grade components are utilized throughout the circuit design with special emphasis on components within the audio path to assure stable, consistent performance.
- * Premium transport and servo drive system assures constant data rate retrieval and unsurpassed tracking performance.
- * Use Burr Brown 96kHz/24bit D/A converter for high resolution and superb audio reproduction.
- * Unique 5-pole linear active LPF (low pass filter) prevents interference from ultrasonic noise commonly found in other CD playback systems.
- * Advanced power supply design incorporates separate windings for the digital, analog and servo circuits to prevent interference and preserve sonic performance.
- * EIA calibrated audio outputs ensure a proper match with preamplifiers and receivers.
- * Provide digital output allow the CD8b to be used as a high-quality transport and provide for future upgrades.
- * Up to 21 tracks may be programmed to playback in desired order.
- * Full-function infrared (IR) remote control with direct track access.

TRANSIT SCREW

A transit screw secures the transport mechanism for protection during shipment. Before making any connections or applying power to the CD6b, remove the transit screw which is located on the underside of the unit.

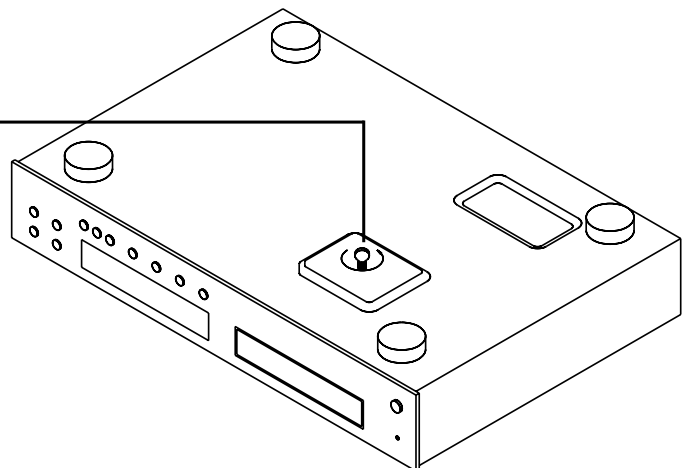

REAR PANEL CONNECTIONS/FRONT PANEL CONTROLS

REAR PANEL

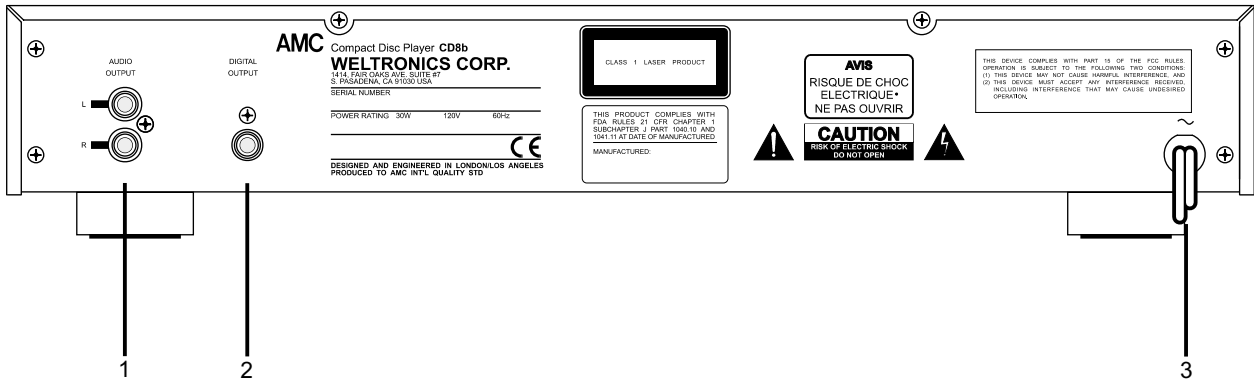

- 1. AUDIO OUTPUT
- 2. DIGITAL OUTPUT

- 3. AC LINE CORD

FRONT PANEL

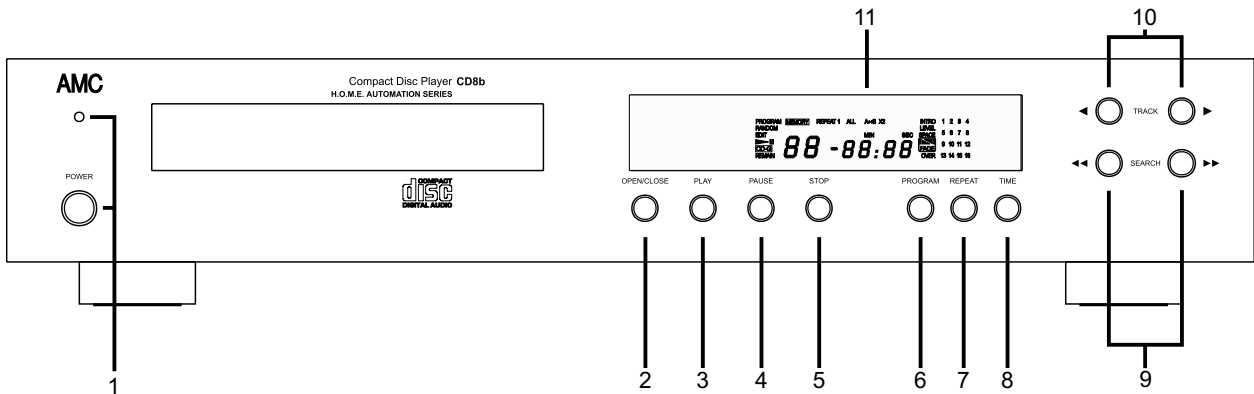

- 1. POWER SWITCH AND POWER INDICATOR
- 2. OPEN/CLOSE
- 3. PLAY
- 4. PAUSE
- 5. STOP

- 6. PROGRAM
- 7. REPEAT
- 8. TIME
- 9. SEARCH
- 10. TRACK
- 11. DISPLAY

REAR PANEL CONNECTIONS

1. AUDIO OUTPUT

Connect the left and right channel unbalanced (RCA) audio outputs to any input on your preamplifier or receiver **except** "Phono" or "Turntable". High-quality interconnection cables are recommended.

2. DIGITAL OUTPUT

Co-axial cable digital output.

3. AC LINE CORD

Plug the AC line cord into a switched outlet on your amplifier or into any AC wall outlet that provides the correct line voltage.

FRONT PANEL CONTROLS

1. POWER SWITCH

The CD player is turned on by depressing the power switch. The LED indicator above the power switch will glow green.

Note: All connections must be completed before turning the power on.

2. OPEN/CLOSE

By pressing the open/close button the disc drawer will open. Pressing it again will close the drawer. If the drawer is opened while a disc is playing, the disc will stop and the drawer will open. An open drawer can also be closed by pressing PLAY or by gently pushing the drawer inward. If the OPEN/CLOSE button is pushed after programming the player, all programming will be erased.

3. PLAY

Place a CD into the open drawer with the label facing up. Press the PLAY button to close the drawer and begin playback. Playback will stop when the STOP button is pressed or when the disc has reached the end.

4. PAUSE

While the disc is playing, press the PAUSE button to suspend playback. Press the PAUSE button again to resume playback.

5. STOP

To stop the CD while playing, press the STOP button. Pressing the STOP button will cancel any repeat-play cycles and the display will show the number of the tracks and total time on the disc.

6. PROGRAMMING

The CD8b can be programmed to play up to 21 tracks in any desired order.

To program playback, start by pressing the PROGRAM button. The MEMORY indicator will illuminate. When the track number displays "00" and the time display indicates "P:01" programming entries may be entered.

a) Use the TRACK button to select the first track in your planned sequence. In the memory mode, the CD8b has a "wrap-around" function. If you TRACK back repeatedly from track "00", the number counts down from the final track of the disc. This provides a convenient way to select high-numbered tracks during programming.

b) Press PROGRAM to store the selected track in memory. The track number will revert back to "00" and the time display will advance to "P:02", showing the player is ready for a second entry.

c) Repeat steps a and b, TRACK and PROGRAM, to select and store other track numbers in memory, up to a maximum of 21 entries.

d) At any point during the program entry process, the TIME button on the player can be pressed to display the total playing time of the program.

e) To review programmed entries, press PROGRAM repeatedly to show programmed entries. When the displayed track number returns to "00", additional tracks may be entered in the memory by repeating steps a and b.

f) To play the stored programs, press PROGRAM followed by PLAY. The word PROGRAM will appear in the upper-right corner of the display indicating that a stored program is being played.

During program playback the TRACK buttons will access only the tracks in the program list. If you want to skip over a portion of a stored program, initiate play and press TRACK to jump over the programmed tracks you don't want to hear.

g) To terminate the programmed play, press STOP. The TRACK and SEARCH buttons will now access any track on the disc. The stored track list, however, still remains in the memory. If you want to play the program again, simply press PROGRAM followed by PLAY. If you want to add new tracks to the program, press PROGRAM repeatedly to review the list until the track number shows "00".

h) To clear the program memory, press **OPEN/CLOSE** to open the drawer or simply switch off the power.

7. REPEAT

This button will allow two different types of endless play modes.

Press the **REPEAT** button once, the word **REPEAT 1** will appear on the display and the selected track will be repeated endlessly until the **STOP** button is pressed.

Press the **REPEAT** button a second time, the word **REPEAT ALL** will appear and the entire disc will repeat until the **STOP** button is pressed.

Press the **REPEAT** button a third time or press the **STOP** button to cancel REPEAT mode. The display and operation will return to normal.

8. TIME

The TIME button will cycle the time display through three different modes.

a. TIME: the elapsed time since the beginning of the current track, in minutes and seconds. (This is the "default" setting, selected automatically when the player is turned on).

b. REMAIN: (track number displayed): shows the total playing time that remains till the end of the current track.

c. REMAIN: (track number blank): The total playing time that remains till the end of the disc. During program play, the remaining time of the program is shown. During program entry, the TIME button displays the total playing time of the tracks in the program.

9. SEARCH

Press and hold **SEARCH** (<< or >>) to find a desired starting point or a certain part of a track. When the **SEARCH** button is pressed and held during playback the output level will be automatically attenuated by 12dB.

10. TRACK

Press **TRACK** (< or >) to find a desired track. Track number is displayed.

11. DISPLAY

When loading a disc and using the OPEN/CLOSE button to close the disc drawer, the TOC (Table of Contents) of the disc will be read and the display will show the number of tracks and the total playing time of all of the tracks on the disc. During play, the following information is displayed:

Track Number

These track numbers are identified on the CD package and are encoded in the disc by the manufacturer.

Time

Shows in minutes and seconds the time elapsed in the music since the beginning of the current track. Pressing the TIME button will display the time remaining until the end of the current track or the playing time remaining until the end of the disc.

Status

Explanation

>	glows to indicate disc is playing.
II	glows to indicate that a disc cannot be read.
REPEAT 1	glows during repeat play of a single track.
REPEAT ALL	glows during repeat play of the entire disc.
REPEAT AB	glows during repeat play from point A to point B.
REMAIN	glows to indicate number of tracks on disc being loaded or the tracks that have been programmed into memory. The number of the track that is playing will flash.
OVER	glows when the disc contains more than 16 tracks.

REMOTE CONTROL

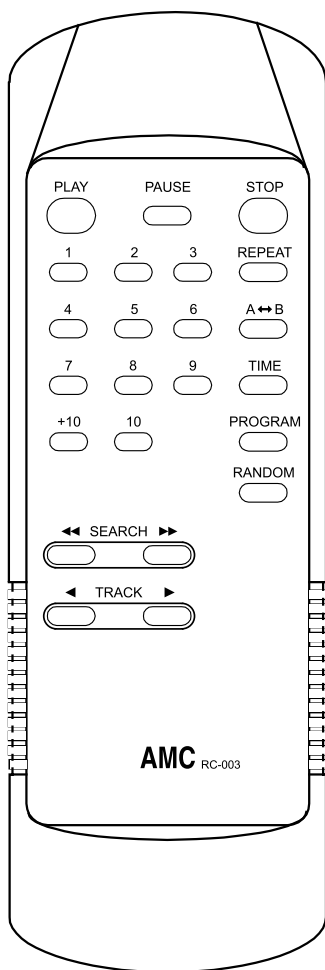

REMOTE CONTROL

An infrared (IR) remote control is provided for convenient operation of the CD8b. The handset provides the same control functions as the front panel PLUS two additional control functions.

NUMERIC KEYPAD (1-10, +10)

Allows direct selection of desired track. Upon entry of the desired track number, the player shifts to the beginning of the track and begins to play.

To select track 8, simply press the "8" button. To select track 24, press the "+10" button twice and then press the "4" button (+10, +10, 4).

RANDOM

Pressing the RANDOM button before or during play will cause the CD8b to play all tracks on the disc in a random order until all tracks have been played. To cancel random play, simply press the RANDOM button again.

SPECIFICATIONS

AUDIO OUTPUT (Ref. 1KHz/0dB, unless otherwise stated):

Disc capacity.....	Single disc, 120 or 80mm
Programming capability.....	21 Tracks
Digital to analogue conversion.....	Enhanced multilevel Delta-Sigma DAC
Digital filter.....	8X over-sampling at a 96Khz sampling rate (Stop band attenuation:82dB, passband ripple: +/-0.002dB)
Analogue filter.....	5-Pole active
Frequency response 5Hz-20KHz.....	<+/-0.3 dB
De-Emphasis error.....	<+/-0.3 dB
Linearity.....	+/-0.5 dB: 0 to -90 dB
Channel separation (20Hz to 20KHz).....	>90 dB
Channel imbalance.....	<+/-0.2 dB
S/N ratio (Aweighted, measured with all zeros test disc).....	105 dB
Dynamic range.....	>100 dB
THD (at 0dB, 1KHz, Aweighted).....	0.0018% (-94.9 dB)
Intermodulation distortion (19 & 20 KHz).....	<100 dB
Output impedance.....	120 ohm
Output level at 0dB.....	2.2 Vrms
Digital error correction.....	CIRC with double error correction in C1 and C2
Wow and flutter.....	Unmeasureable (Quartz crystal accuracy)
Remote control unit.....	Full functional with numeric keypad

S/PDIF DIGITAL OUTPUT:

Digital Output level.....	0.5 Vpp
Load impedance.....	75 ohm
Peak emission wave length.....	660 nm

PHYSICAL:

Dimensions (W x H x D).....	430x82x300 mm
Net weight.....	6.5 Kgs
Shipping weight (4 pieces).....	28.5 Kgs
Power consumption.....	30 W

Weltronics Corp. reserved the right to improve its products at any time. Specifications are subject to change without notice.

SAFETY INSTRUCTION

1. READ INSTRUCTIONS

All the safety and operating instructions should be read before the appliance is operated.

2. RETAIN INSTRUCTIONS

The safety and operating instructions should be retained for future reference.

3. HEED WARNINGS

All warnings on the appliance and in the operating instructions should be adhered to.

4. FOLLOW INSTRUCTIONS

All operating and use instructions should be followed.

5. WATER AND MOISTURE

The appliance should not be used near water - for example, near a bathtub, washbowl, kitchen sink, laundry tub, in a wet basement, or near a swimming pool, etc.

6. CARTS AND STANDS

The appliance should be used only with a cart or stand that is recommended by the manufacturer.

- 6A. An appliance and cart combination should be moved with care. Quick stops, excessive force, and uneven surfaces may cause the appliance and cart combination to overturn.



7. WALL OR CEILING MOUNTING

This equipment is not designed for use mounted on a wall or a ceiling.

8. VENTILATION

The appliance should be situated so that its location or position does not interfere with its proper ventilation. For example, the appliance should not be situated on a bed, sofa, rug, or similar surface that may block the ventilation openings, or placed in a built-in installation, such as bookcase or cabinet that may impede the flow of air through the ventilation openings.

9. HEAT

The appliance should be situated away from heat sources such as radiators, heat registers, stoves, or other appliances (including amplifiers) that produce heat.

10. POWER SOURCES

The appliance should be connected to a power supply only of the type described in the operating instructions or as marked on the appliance.

11. POWER-CORD PROTECTION

Power-supply cords should be routed so that they are not likely to be walked on or pinched by items placed upon or against them, paying particular attention to cords at plugs, convenience receptacles, and the point where they exit from the appliance.

12. CLEANING

The appliance should be cleaned only as recommended by the manufacturer.

13. NON USE PERIODS

The power cord of the appliance should be unplugged from the outlet when left unused for a long period of time.

14. OBJECT AND LIQUID ENTRY

Care should be taken so that objects do not fall and liquids are not spilled into the enclosure through openings.

15. SERVICING

The user should not attempt to service the appliance beyond that described in the operating instructions. All other servicing should be referred to qualified service personnel.

16. DAMAGE REQUIRING SERVICE

The appliance should be serviced by qualified service personnel when:

- The power-supply cord or the plug has been damaged; or
- Objects have fallen, or liquid has been spilled into the appliance; or
- The appliance has been exposed to rain; or
- The appliance does not appear to operate normally or exhibits a marked change in performance; or
- The appliance has been dropped, or the enclosure is damaged.

17. POWER LINES

(APPLIES TO TUNER AND RECEIVERS ONLY)

An outdoor antenna should be located away from power lines.

18. OUTDOOR ANTENNA GROUNDING

(APPLIES TO TUNER AND RECEIVERS ONLY)

If an outside antenna is connected to the receiver, be sure the antenna system is grounded so as to provide some protection against voltage surges and built up static charges.

Section 810 of the National Electrical Code, ANSI/NFPA No. 70-1984, provides information with respect to proper grounding of the mast and supporting structure, grounding of the lead-in wire to an antenna discharge unit, size of grounding conductors, location of antenna-discharge unit, connection to grounding electrodes, and requirements for the grounding electrode. See Figure.

- Use No. 10 AWG (5.3 mm²) copper, No. 8 AWG (8.4 mm²) aluminum, No. 17 AWG (1.0 mm²) copper-clad steel or bronze wire, or larger, as a ground wire.
- Secure antenna lead-in and ground wires to house with stand-off insulators spaced from 4-6 feet (1.22-1.83 m) apart.
- Mount antenna discharge unit as close as possible to where lead-in enters house.
- Use jumper wire not smaller than No.6 AWG (13.3 mm²) copper, or the equivalent, when a separate antenna-grounding electrode is used. See NEC Section 810-21(j).

Antenna Grounding According to the National Electrical Code

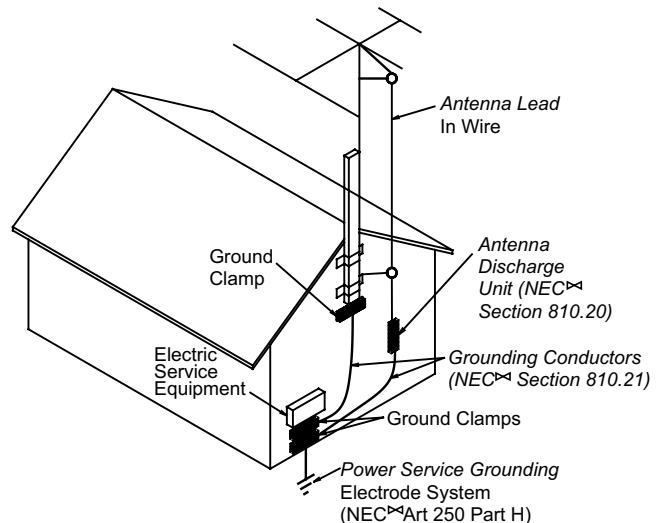

† National Electrical Code
Available from Library, book
stores, or National Fire Protection
Association (Batterymarch Park,
Quincy, MA 02269).

WELTRONICS CORP.

LONDON/L.A.

AMC Web: <http://www.amchome.com>

PN: 21-4136